



US005894906A

**United States Patent** [19]  
**Weber**

[11] **Patent Number:** **5,894,906**  
[45] **Date of Patent:** **Apr. 20, 1999**

[54] **ACCIDENT RESPONSIVE SAFETY RELEASE FOR A MOTOR VEHICLE'S REAR DOOR CHILD-LOCK DEVICE**

[76] Inventor: **Harold J. Weber**, P.O. Box 6161, 560 Washington St., Holliston, Mass. 01746

[21] Appl. No.: **08/747,163**

[22] Filed: **Nov. 8, 1996**

[51] Int. Cl.<sup>6</sup> ..... **B60K 28/10**

[52] U.S. Cl. .... **180/274; 180/281**

[58] Field of Search ..... **180/274, 271, 180/281**

[56] **References Cited**

**U.S. PATENT DOCUMENTS**

2,714,521	5/1955	Graham	180/281
4,381,829	5/1983	Montaron	180/274
4,785,907	11/1988	Aoki et al.	180/274
5,574,315	11/1996	Weber	307/10.1

**OTHER PUBLICATIONS**

BMW Product Brochure OLY2-596-200, p. 35, col. 2, (copyright 1996, BMW of North America, Inc., PO Box 5090, North Branch, NJ 08876).

*Primary Examiner*—Kenneth R. Rice

[57] **ABSTRACT**

A motor vehicle rear door anti-egress CHILD-LOCK device safety release responsive to an accident involving the motor vehicle whereby a preset CHILD-LOCK device may be immediately unset upon collision between the motor vehicle and another object. The anti-egress CHILD LOCK release enables immediate post-accident unlatchability of the motor vehicle's rear door by an occupant of the motor vehicle and allow unencumbered egress from the motor vehicle. The result is reduced risk particularly for automobile rest-seat passengers including children and adults who might otherwise remain dangerously entrapped within a wrecked vehicle and suffering risk for further post-accident physical or psychological trauma or even death due to bodily entrapment, fire or explosion which may follow an accident.

**20 Claims, 8 Drawing Sheets**

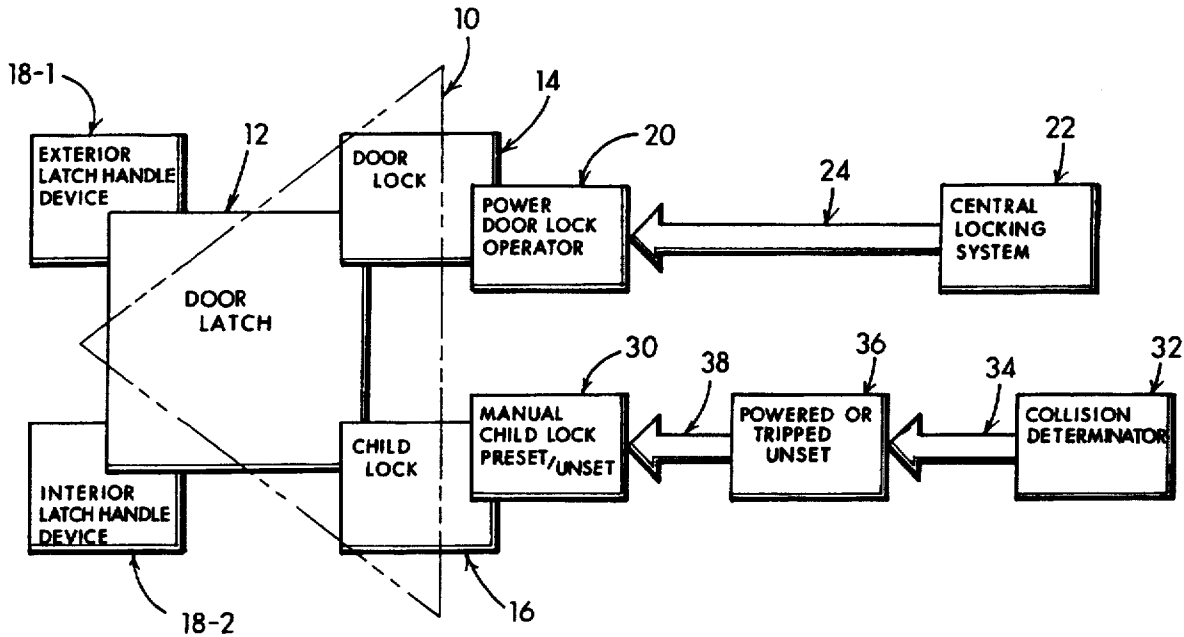

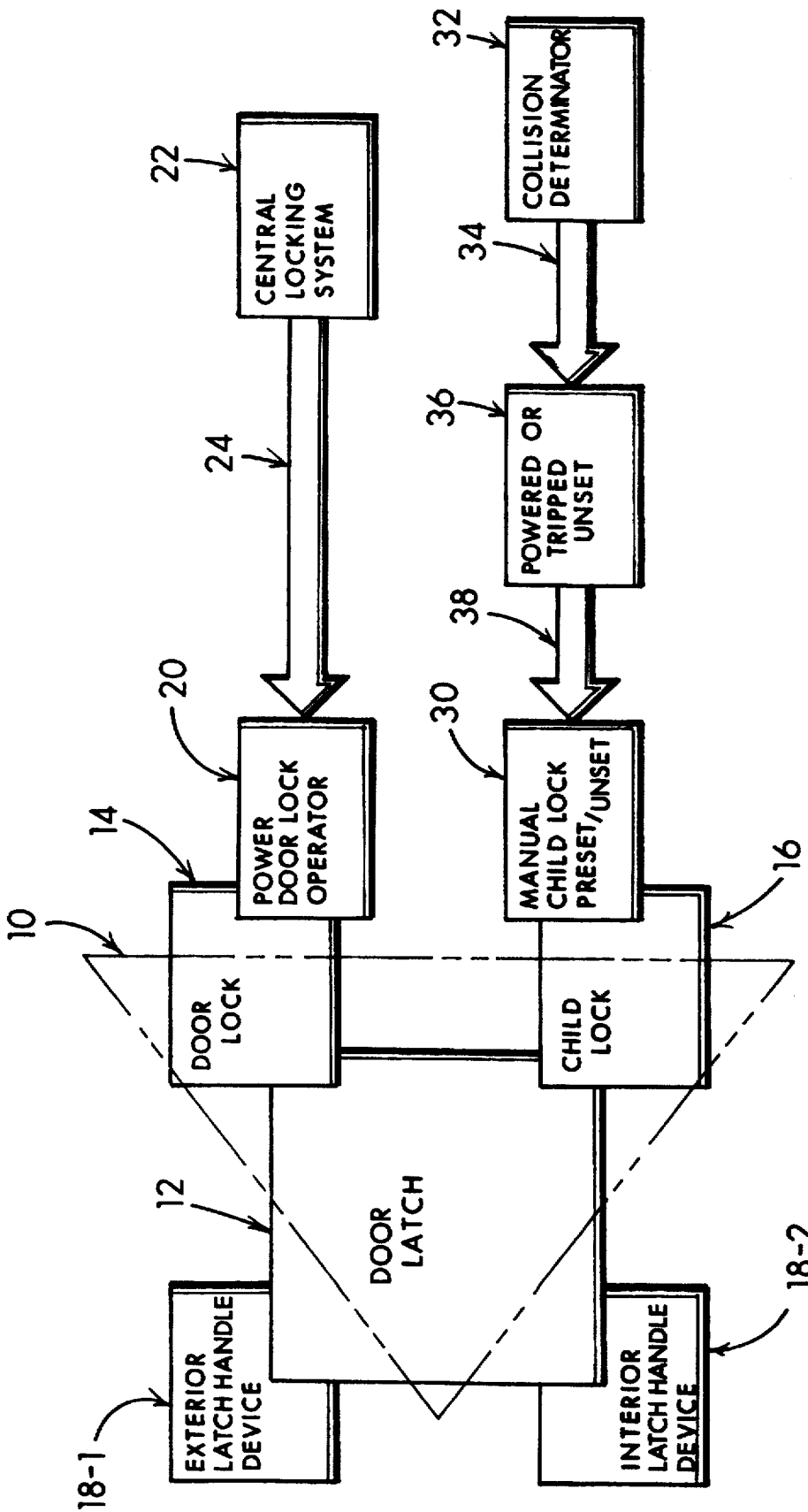
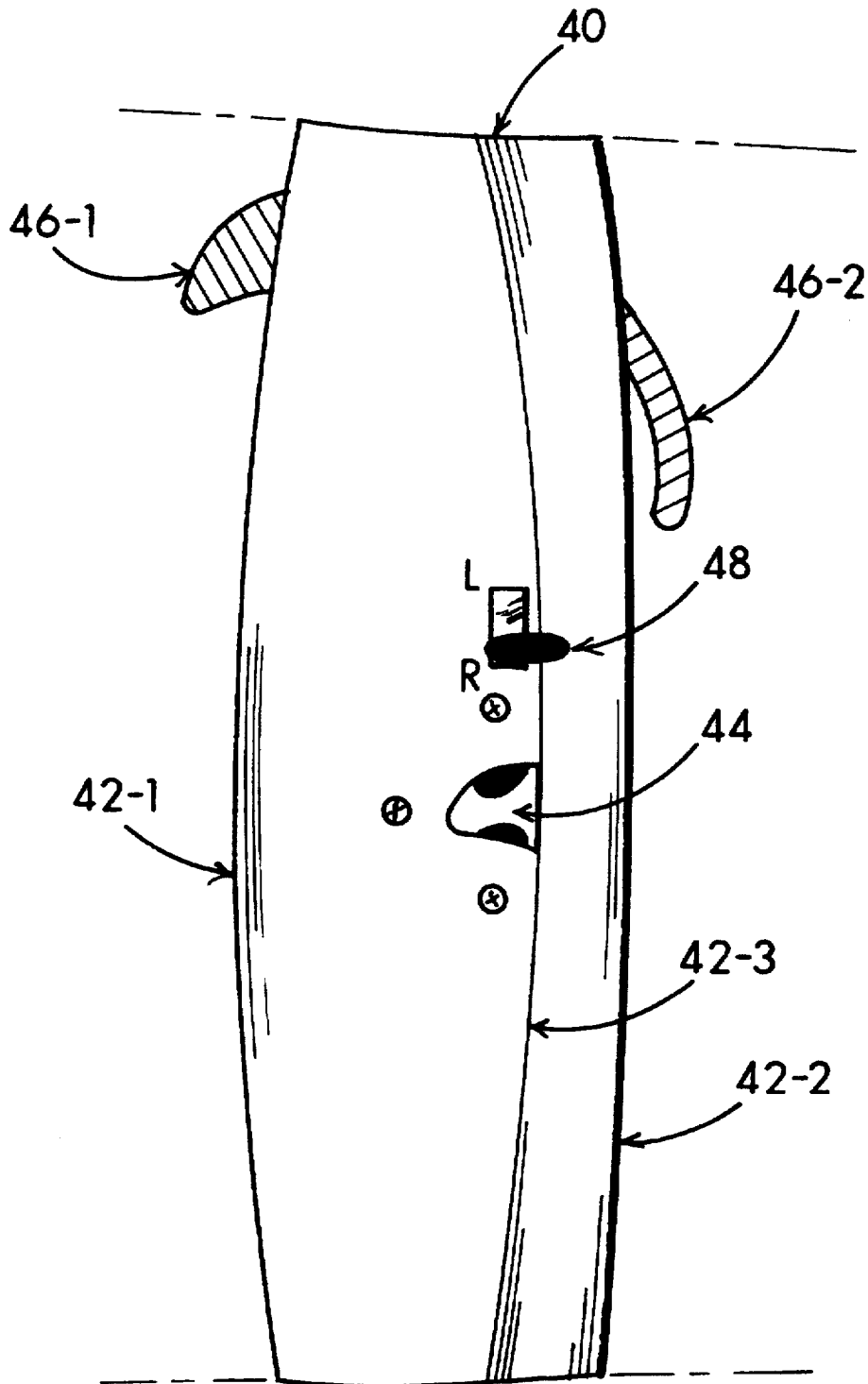

FIG. 1



**FIG. 2**

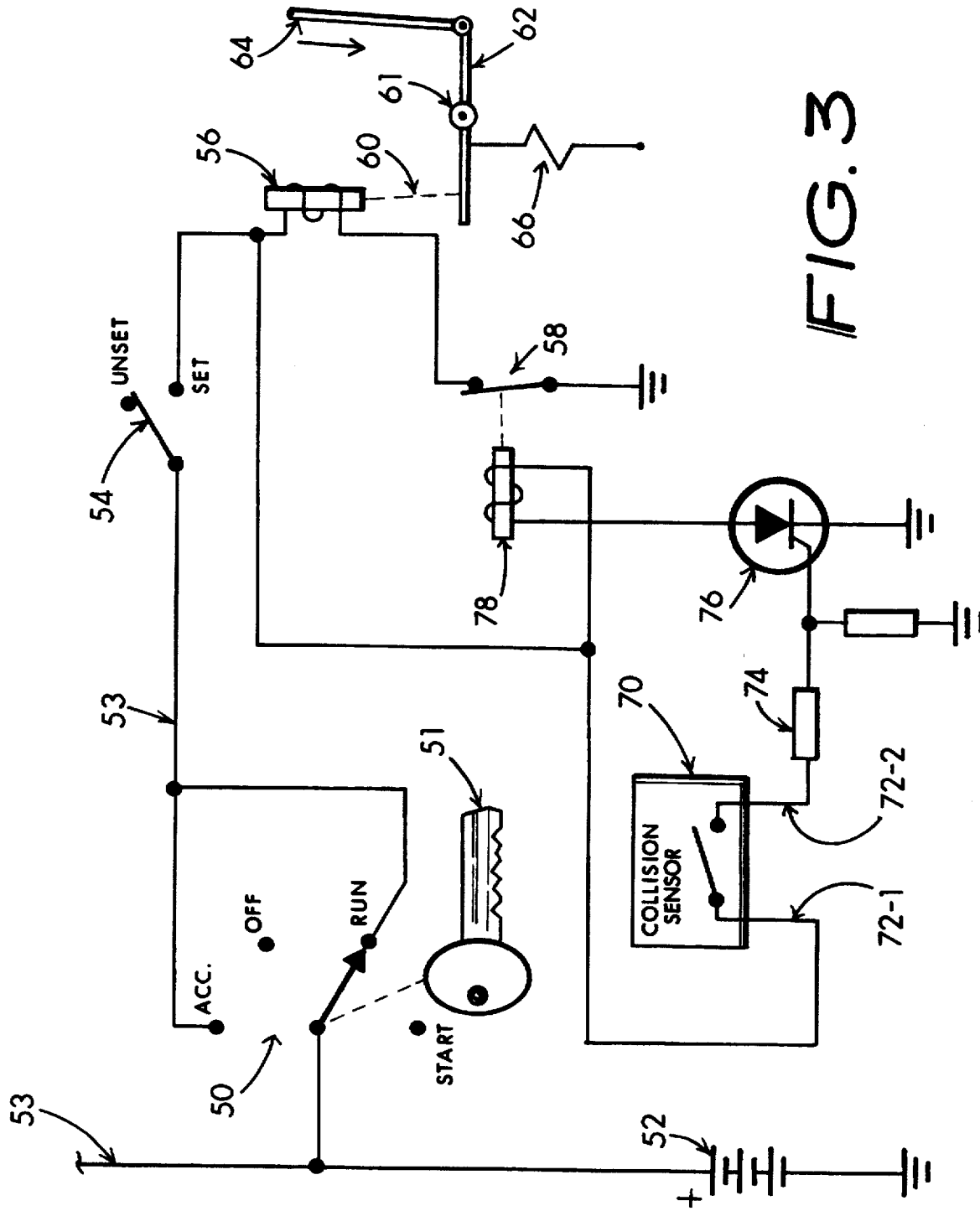

FIG. 3

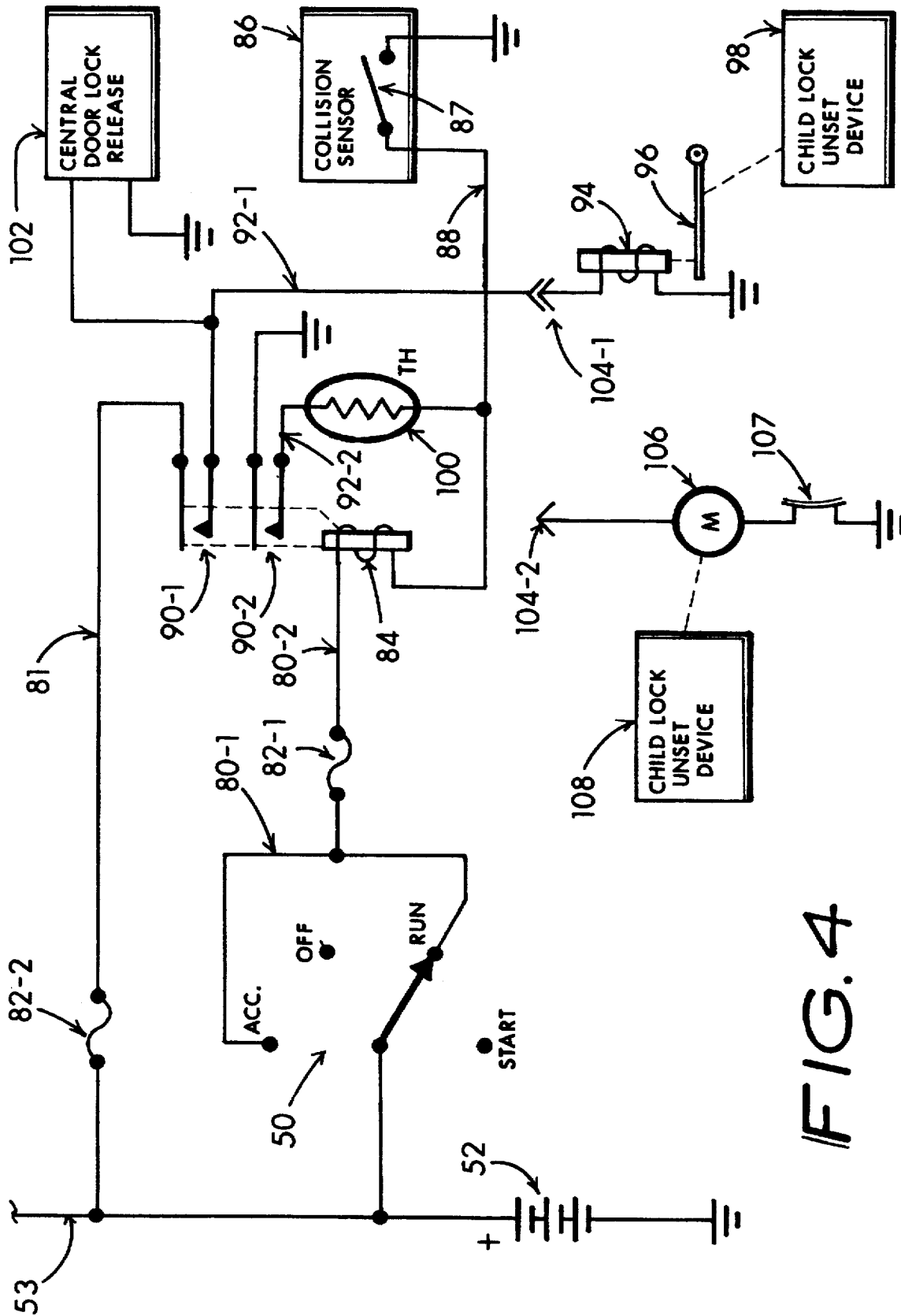

FIG. 4

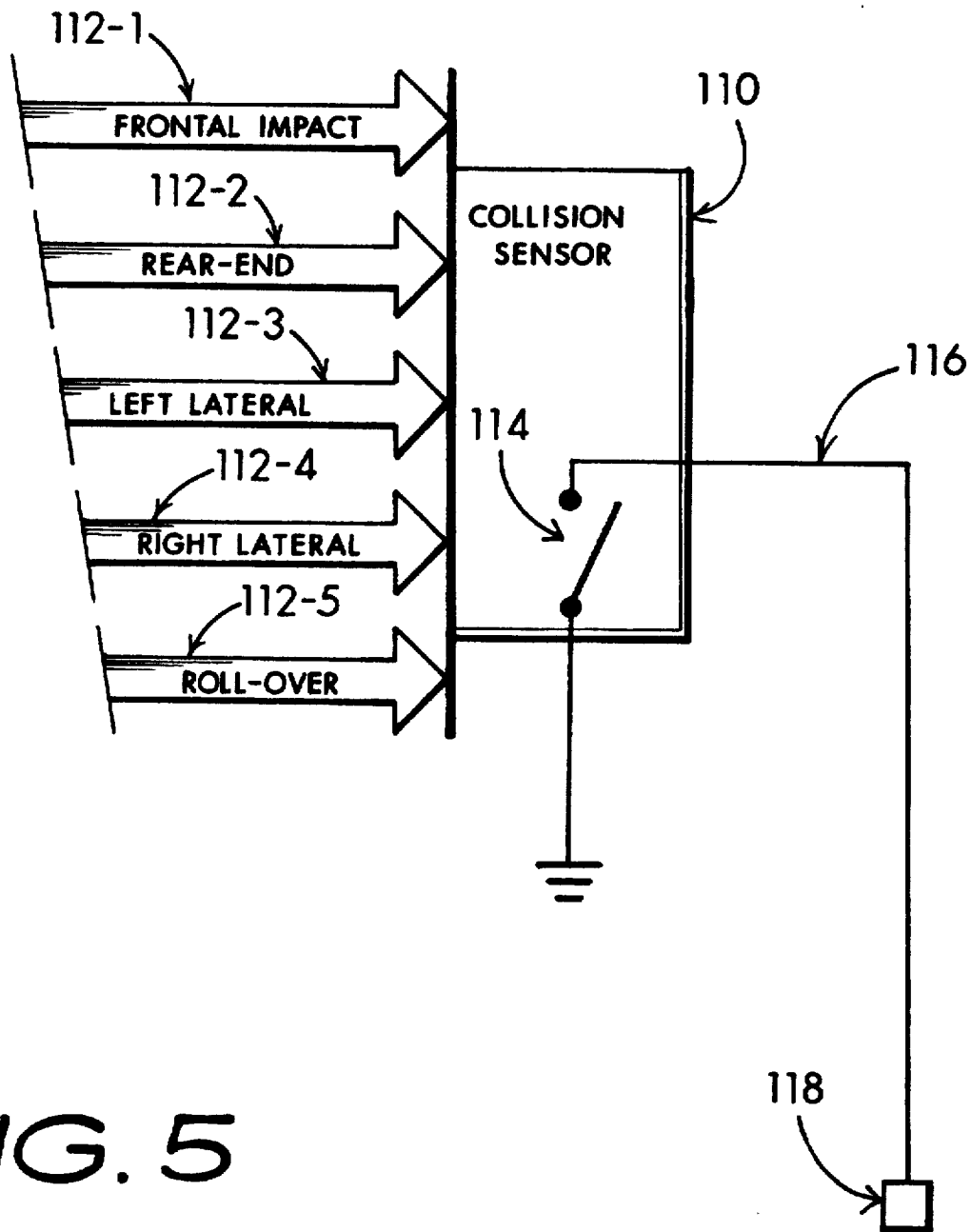

FIG. 5

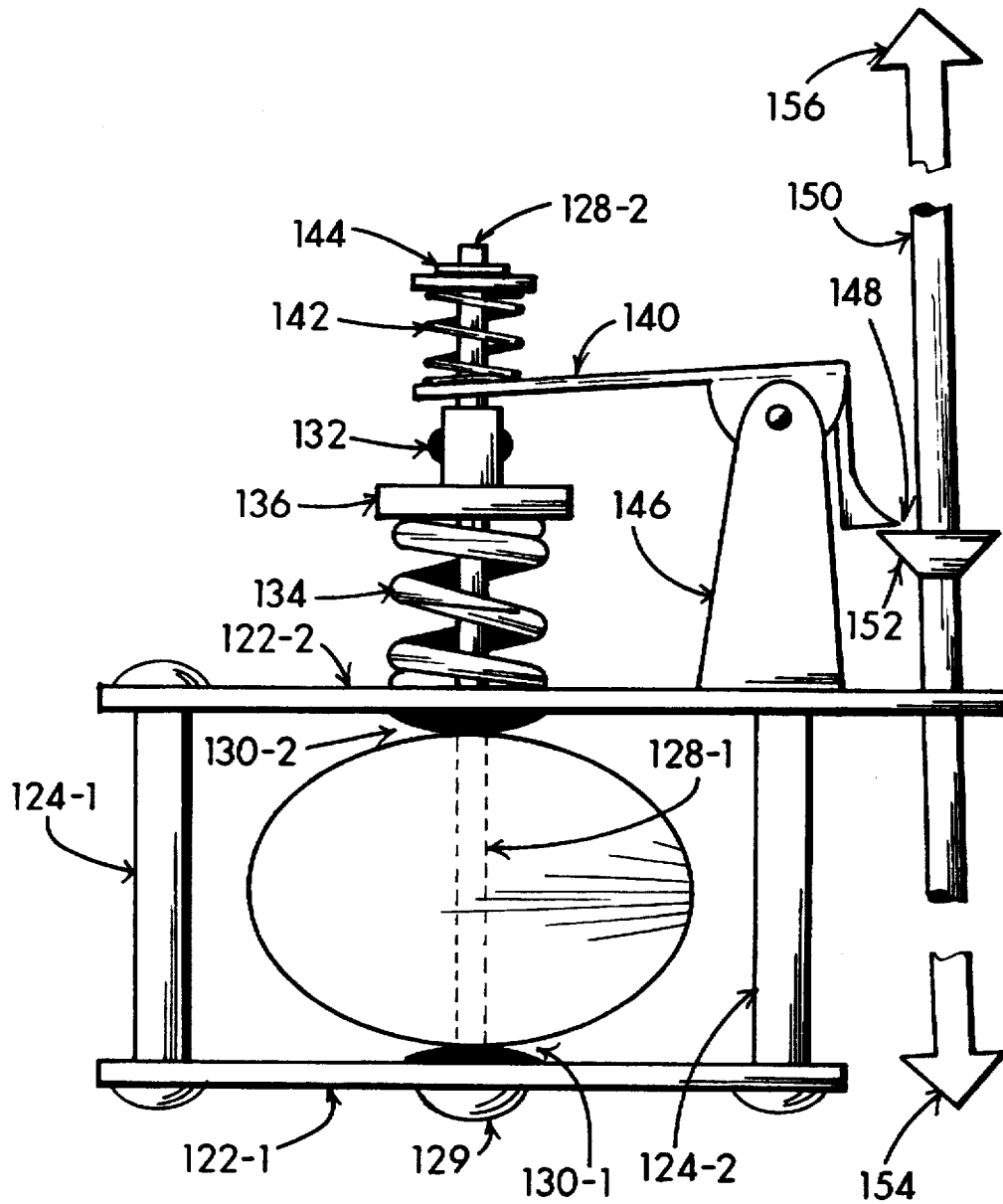
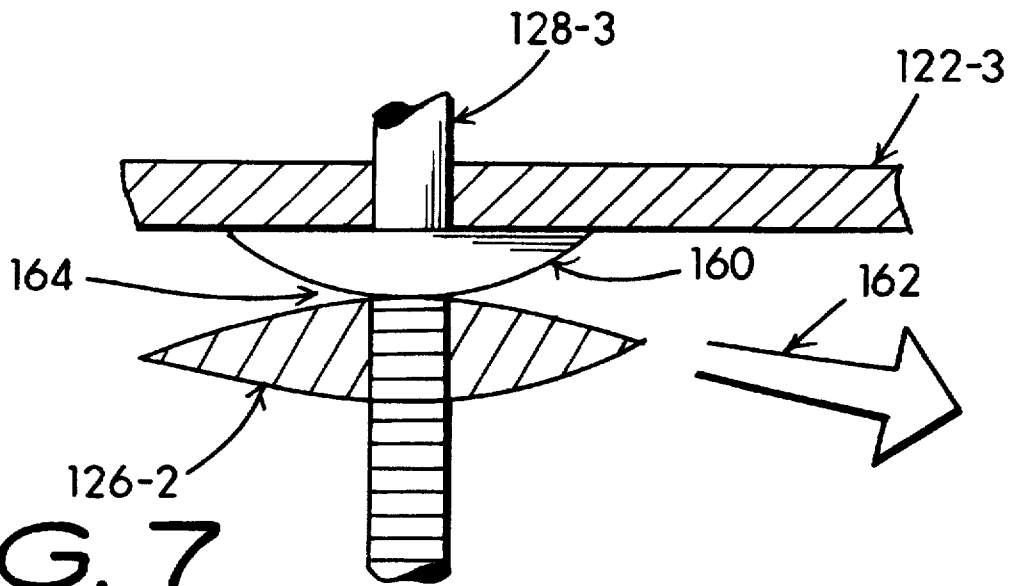
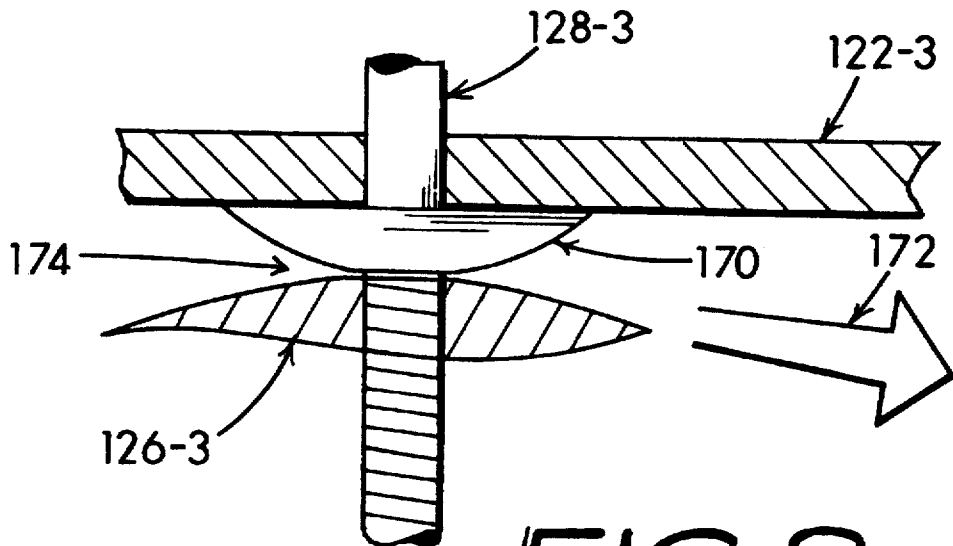

FIG. 6



**FIG. 7**



**FIG. 8**

